



US 20150028307A1

(19) **United States**

(12) **Patent Application Publication**  
**KIM et al.**

(10) **Pub. No.: US 2015/0028307 A1**  
(43) **Pub. Date: Jan. 29, 2015**

(54) **ORGANIC LIGHT EMITTING DISPLAY**

(52) **U.S. Cl.**

(71) Applicant: **LG DISPLAY CO., LTD.**, Seoul (KR)

CPC ..... **H01L 51/5253** (2013.01); **H01L 51/56**  
(2013.01); **H01L 51/5246** (2013.01); **H01L**  
**51/5259** (2013.01)

(72) Inventors: **Kyungman KIM**, Goyang-si (KR);  
**Myungseop KIM**, Goyang-si (KR)

USPC ..... **257/40**; 438/28

(21) Appl. No.: **14/330,924**

(57) **ABSTRACT**

(22) Filed: **Jul. 14, 2014**

(30) **Foreign Application Priority Data**

Jul. 29, 2013 (KR) ..... 10-2013-0089590

**Publication Classification**

(51) **Int. Cl.**  
**H01L 51/52** (2006.01)  
**H01L 51/56** (2006.01)

An organic light emitting display including a back plane including an active area on which an image is displayed, and a bezel area outside the active area; a pixel array on the active area and configured to display the image; an encapsulation plate encapsulating the pixel array; a transparent adhesive film free of a moisture absorption filler, formed on the active area and disposed between the encapsulation plate and the back plane; and a darn including a sealant with a moisture absorption filler formed in the bezel area and adjoining the adhesive layer so as to limit moisture from penetrating into the pixel array.

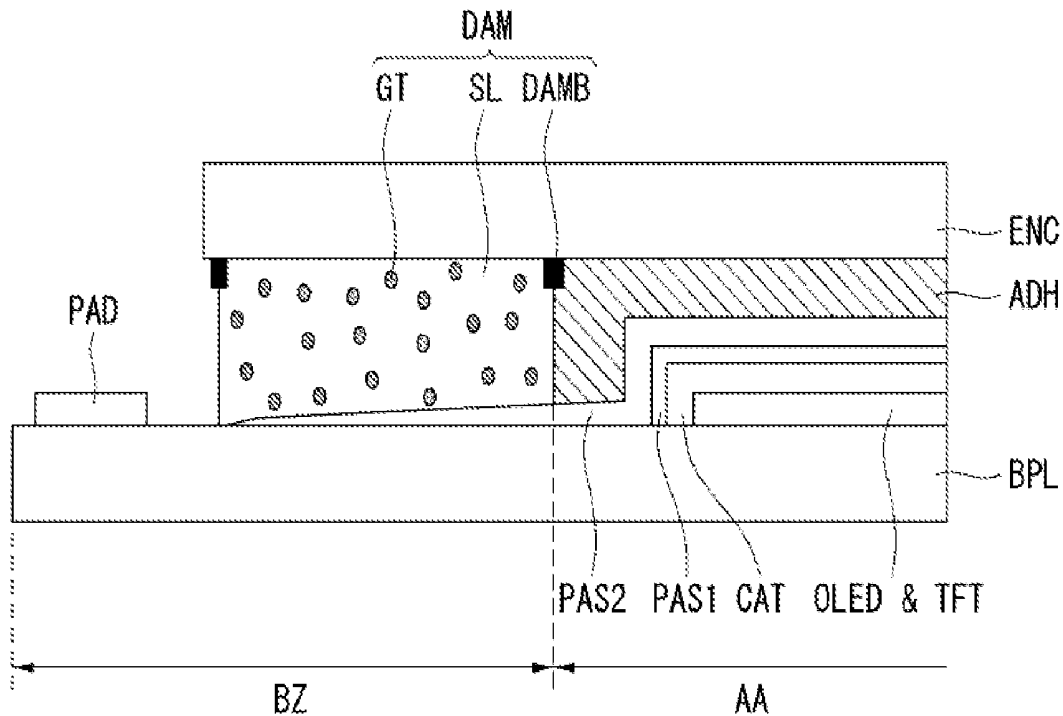

FIG. 1

(RELATED ART)

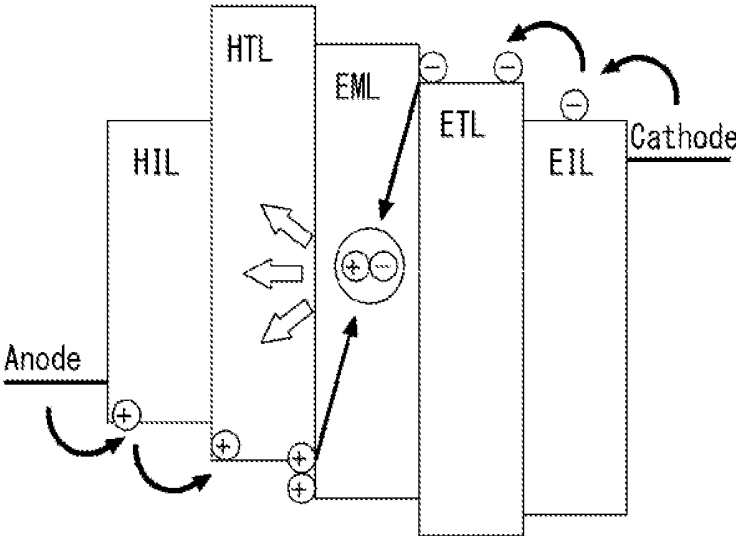

FIG. 2

(RELATED ART)

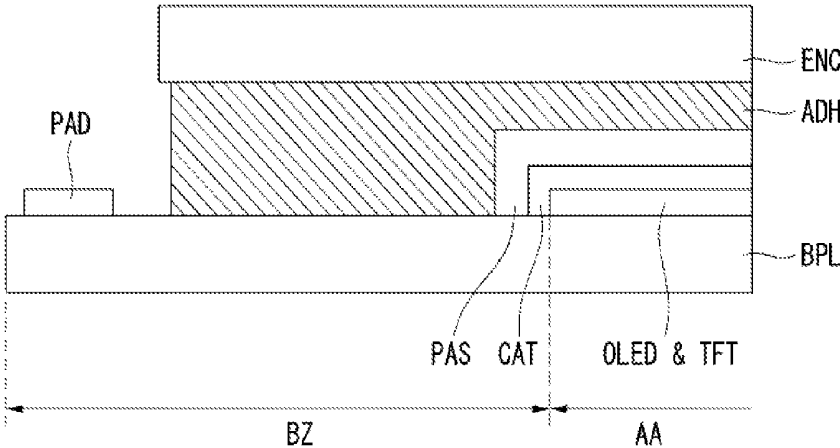

FIG. 3

(RELATED ART)

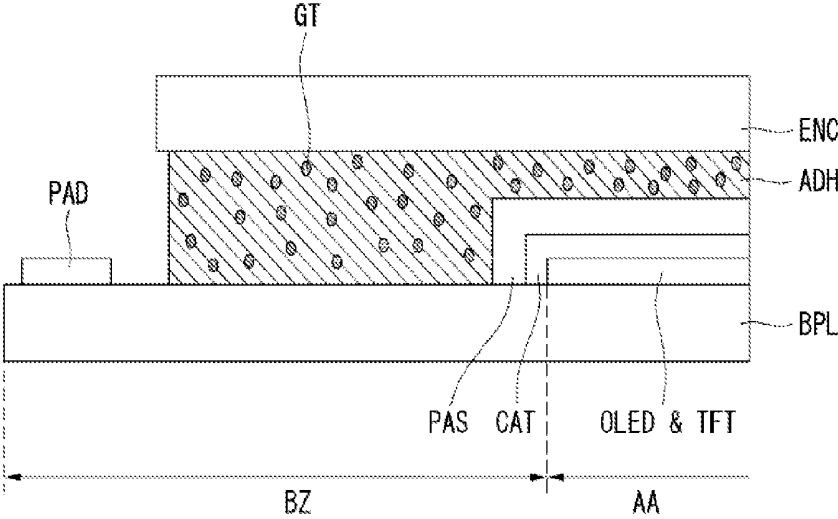

FIG. 4

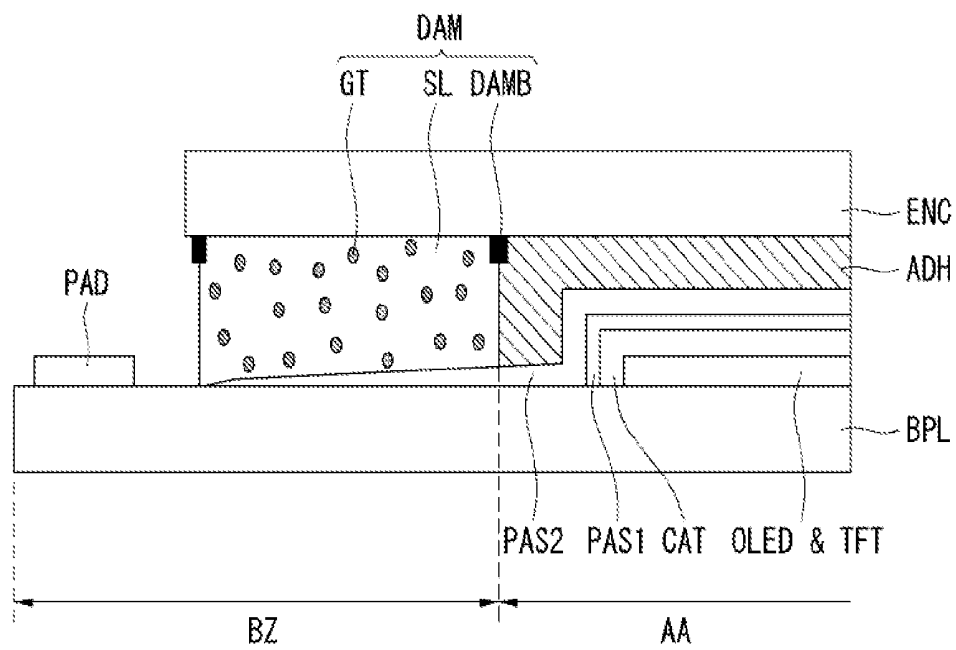

FIG. 5

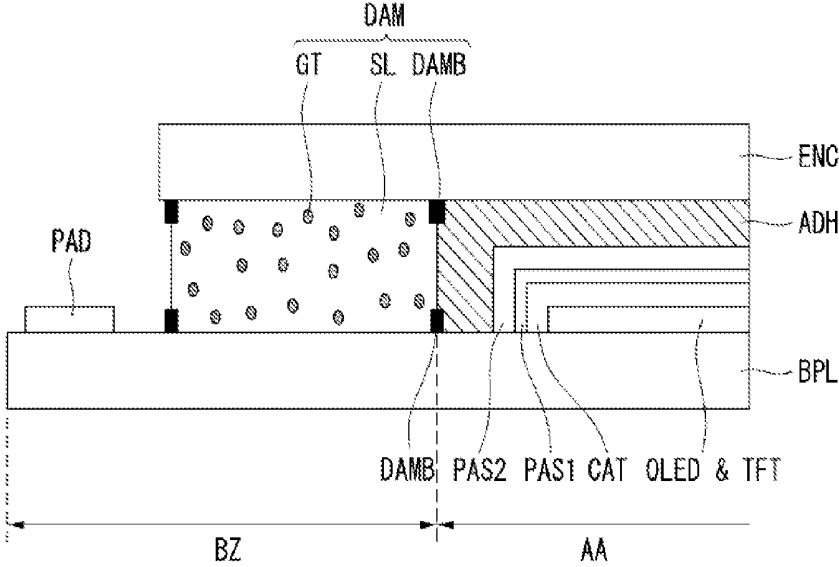

FIG. 6

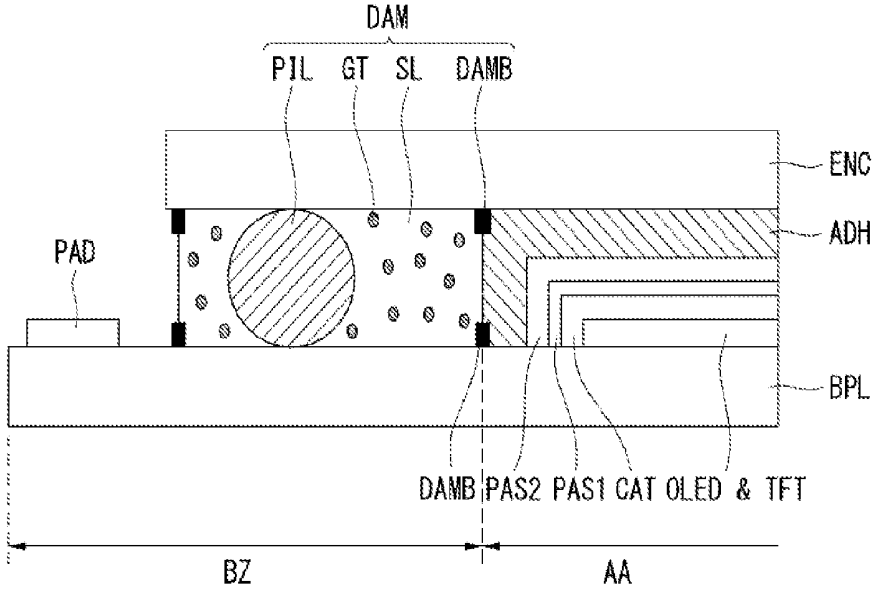

FIG. 7

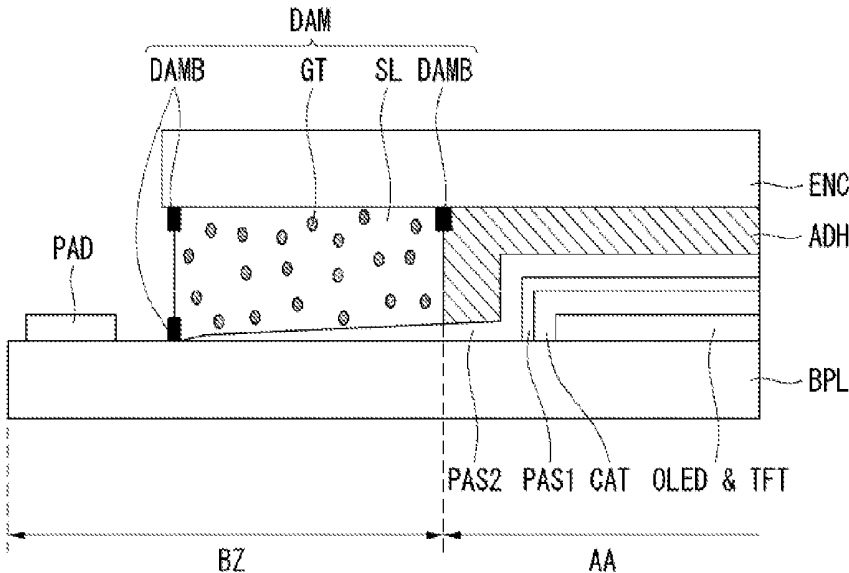

FIG. 8

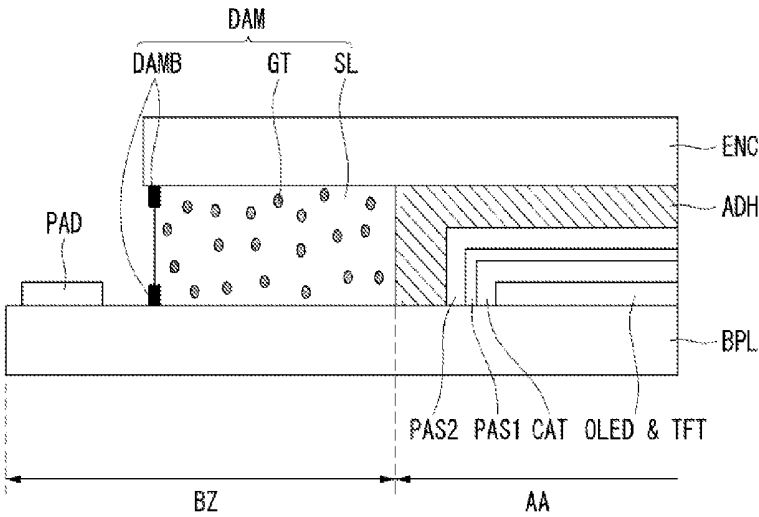

FIG. 9

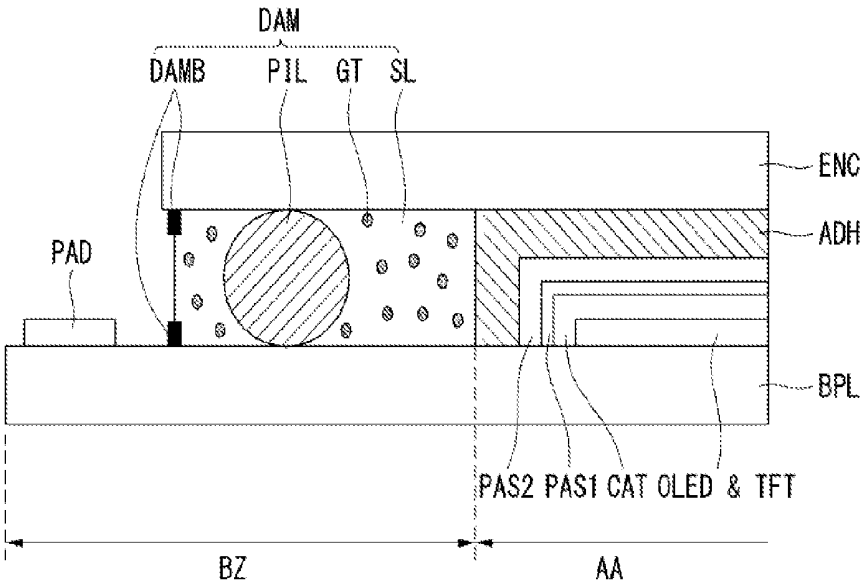
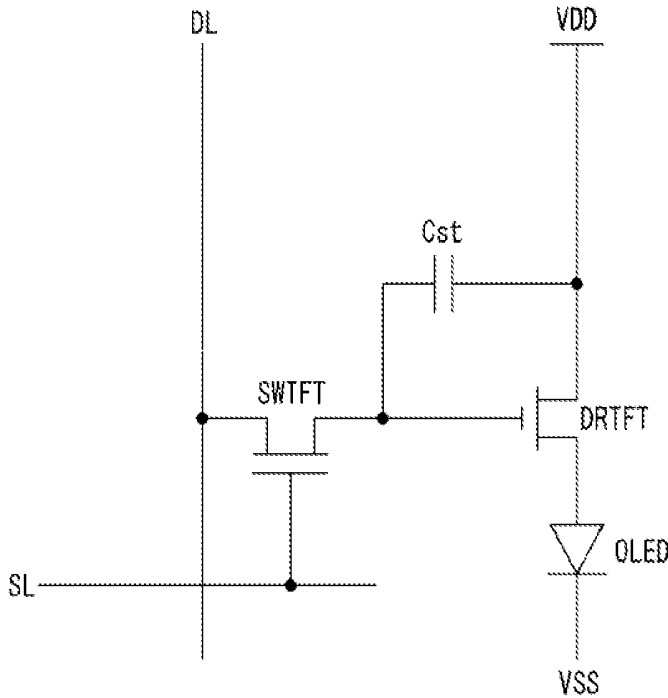

FIG. 10



## ORGANIC LIGHT EMITTING DISPLAY

[0001] This application claims the benefit of Korean Patent Application No. 10-2013-0089590 filed on Jul. 29, 2013, the entire contents of which is incorporated herein by reference for all purposes as if fully set forth herein.

### BACKGROUND OF THE INVENTION

[0002] 1. Field of the Invention

[0003] Embodiments of the invention relate to an organic light emitting display encapsulation technology.

[0004] 2. Discussion of the Related Art

[0005] Each pixel in an organic light emitting display includes an organic light emitting diode (OLED) having a self-emitting structure. As shown in FIG. 1, the OLED includes a stack of organic compound layers including a hole injection layer Hit, a hole transport layer HTL, an emission layer EML, an electron transport layer ETL, an electron injection layer EIL, etc., between an anode and a cathode. The organic light emitting display displays an image using a phenomenon, in which the OLED emits light when electrons and holes are combined in an organic layer through a current flowing in a fluorescence or phosphorescence organic thin film.

[0006] In addition, the organic light emitting display may be variously classified depending on kinds of emission materials, an emission method, an emission structure, a driving method, etc. The organic light emitting display may be classified into a fluorescent emission type and a phosphorescent emission type depending on the emission method. Further, the organic light emitting display may be classified into a top emission type and a bottom emission type depending on the emission structure. Further, the organic light emitting display may be classified into a passive matrix OLED type and an active matrix OLED type depending on the driving method.

[0007] However, characteristics of the organic compounds are sharply degraded when organic compounds of the OLED are exposed to moisture. Thus, the moisture penetrating into the pixels decreases the reliability and lifespan of the organic light emitting display. An encapsulation method is used to limit the degradation of the OLEDs resulting from the penetration of moisture and oxygen. One example of the encapsulation technology is disclosed in Korean Patent Laid-open Publication Nos. 10-2013-0055544 (May 28, 2013) and 10-2013-0058711 (Jun. 4, 2013) corresponding to the present applicant, and which are hereby incorporated by reference in their entirety.

[0008] In more detail, an encapsulation technology illustrated in FIG. 2 attaches a back plane BPL and an encapsulation plate ENC using an adhesive film ADH. The back plane BPL includes a pixel array OLED & TFT formed on a substrate. The pixel array OLED & TFT includes data lines, scan lines crossing the data lines, and pixels each including an OLED and a thin film transistor (TFT). The pixels are also arranged in a matrix form.

[0009] Further, the pixel array OLED & TFT are covered with a passivation layer PAS and are formed in an active area AA, on which an image is displayed. In FIG. 2, "PAD" denotes a data pad or a scan pad connected to an output terminal of a drive integrated circuit (IC) formed at an end of the data line or the scan line; "BZ" denotes a bezel on which the image is not displayed at an edge of a display panel; and "CAT" denotes a cathode of the OLED. In the encapsulation technology illustrated in FIG. 2, there is no barrier capable of

blocking moisture (H<sub>2</sub>O) penetrating into the pixel array OLED & TFT. Thus, the reliability and the lifespan of the organic light emitting display adopting the encapsulation technology illustrated in FIG. 2 is reduced.

[0010] Another encapsulation technology is illustrated in FIG. 3 and includes a back plane BPL and an encapsulation plate ENC attached using an adhesive film ADH. Moisture absorption fillers GT are also added to the inside of the adhesive film ADH to help absorb and prevent the moisture from penetrating or exposing the pixel array OLED & TFT.

[0011] However, even though the moisture absorption fillers GT may increase the reliability and the lifespan of the organic light emitting display, the fillers GT are also distributed in the active area AA in FIG. 3. Thus, light emitted from the active area AA is scattered by the moisture absorption fillers GT, and the display image is blurred due to a haze effect. Therefore, it is difficult to apply the encapsulation technology illustrated in FIG. 3 to the top emission type organic light emitting display, in which light of the display image is emitted through the encapsulation plate ENC.

### SUMMARY OF THE INVENTION

[0012] Accordingly, an object of the present invention is to address the above-noted and other problems.

[0013] Another object of the present invention is to provide a novel encapsulation method for an organic light emitting display that decreases the amount of moisture penetrating into the OLED & TFT.

[0014] Yet another object of the present invention is to provide a novel encapsulation method for an organic light emitting display that increases the reliability and the lifespan of the organic light emitting display.

[0015] To achieve these and other advantages and in accordance with the purpose of the present invention, as embodied and broadly described herein, the present invention provides in one aspect an organic light emitting display including a back plane including an active area on which an image is displayed, and a bezel area outside the active area; a pixel array on the active area and configured to display the image; an encapsulation plate encapsulating the pixel array; a transparent adhesive film free of a moisture absorption filler, formed on the active area and disposed between the encapsulation plate and the back plane; and a dam including a sealant with a moisture absorption filler formed in the bezel area and adjoining the adhesive layer so as to limit moisture from penetrating into the pixel array. The present invention also provides a corresponding method of manufacturing an organic light emitting display.

[0016] Further scope of applicability of the present invention will become apparent from the detailed description given hereinafter. However, it should be understood that the detailed description and specific examples, while indicating preferred embodiments of the invention, are given by illustration only, since various changes and modifications within the spirit and scope of the invention will become apparent to those skilled in the art from this

### BRIEF DESCRIPTION OF THE DRAWINGS

[0017] The accompanying drawings, which are included to provide a further understanding of the invention and are incorporated in and constitute a part of this specification,

illustrate embodiments of the invention and together with the description serve to explain the principles of the invention. in the drawings:

**[0018]** FIG. 1 is an overview illustrating a structure and an emission principle of an OLED;

**[0019]** FIGS. 2 and 3 are cross-sectional views illustrating a related art encapsulation technology;

**[0020]** FIGS. 4 and 5 are cross-sectional views illustrating an organic light emitting display encapsulation technology according to an embodiment of the invention;

**[0021]** FIG. 6 is a cross-sectional view illustrating an organic light emitting display encapsulation technology according to another embodiment of the invention;

**[0022]** FIGS. 7 to 9 are cross-sectional views illustrating different patterns of a dam bank positioned around the inside of a sealant shown in FIGS. 4 to 6 according to an embodiment of the invention; and

**[0023]** FIG. 10 is an equivalent circuit diagram of a pixel.

#### DETAILED DESCRIPTION OF THE EMBODIMENTS

**[0024]** Reference will now be made in detail to embodiments of the invention, examples of which are illustrated in the accompanying drawings. Wherever possible, the same reference numbers will be used throughout the drawings to refer to the same or like parts. It will be paid attention that detailed description of known arts will be omitted if it is determined that the arts can mislead the embodiments of the invention.

**[0025]** As shown in FIGS. 4 and 5, an organic light emitting display according to an embodiment of the invention includes a transparent adhesive film ADH for attaching a back plane BPL and an encapsulation plate ENC and a dam DAM formed at an edge of the back plane BPL.

**[0026]** Each of the back plane BPL and the encapsulation plate ENC may be manufactured using a glass substrate, a plastic substrate, or a metal substrate. In a top emission type organic light emitting display, the encapsulation plate is manufactured using a substrate formed of a transparent material. In a bottom emission type organic light emitting display, the back plane is manufactured using a substrate formed of a transparent material.

**[0027]** Further, the transparent adhesive film ADH is an adhesive film with a high transparency, and as shown in FIG. 4 does not include moisture absorption fillers. In more detail, the transparent adhesive film ADH includes a transparent base film and an adhesive applied to both surfaces of the transparent base film. A release film, is also attached to the adhesive. When the encapsulation plate ENC is attached to the back plane BPL, the adhesive applied to both surfaces of the transparent base film is exposed by removing the release film.

**[0028]** A method for attaching the encapsulation plate ENC to the back plane BPL, using the transparent adhesive film ADH forms a dam DAM. In more detail, the transparent adhesive film ADH can be formed on the encapsulation plate ENC and then the encapsulation plate ENC can be attached to the back plane BPL using a hot roll lamination method, a hot press method, or a vacuum press method, etc. when the encapsulation plate ENC is aligned on the back plane BPL with the dam DAM and the transparent adhesive film ADH interposed therebetween.

**[0029]** Further, the transparent adhesive film ADH attaches the encapsulation plate ENC to the back plane BPL in the

active area AA. When the organic light emitting display according to the embodiment of the invention is configured as the top emission type organic light emitting display, a transmittance and an aperture ratio of the active area AA is increased because of the high transparency of the transparent adhesive film ADH.

**[0030]** As shown, the dam DAM is formed between the back plane BPL and the encapsulation plate ENC at the edge of the back plane BPL, thereby enhancing an adhesive strength between the back plane BPL and the encapsulation plate ENC and thus blocking moisture. The dam DAM is also formed in the bezel area BZ outside the active area AA. The dam DAM includes a sealant SL and moisture absorption fillers GT distributed in the sealant SL. The sealant SL is a thermosetting and ultraviolet (UV) curable sealant. For example, the sealant SL may be an epoxy-based or acrylic-based sealant, to which a thermosetting accelerator and/or a photoinitiator are added. The sealant SL also attaches the back plane BPL to an edge of the encapsulation plate ENC and enhances an adhesive strength therebetween.

**[0031]** Further, the moisture absorption fillers GT are formed by grinding a material capable of absorbing moisture to form small size particles and uniformly distributing the particles in the sealant SL. The material of the moisture absorption fillers GT is not limited. For example, the moisture absorption fillers GT may be formed of alkali metal oxide, silica, porous zeolite, other organic moisture absorbents, or other inorganic moisture absorbents. A moisture reactive absorbent may use one or a mixture of at least two of a metal powder such as alumina, metal oxide, metal salt, or phosphorus pentoxide (P<sub>2</sub>O<sub>5</sub>), etc.

**[0032]** A physical absorbent may use silica, zeolite, titania, zirconia, or montmorillonite, etc. In the embodiment disclosed herein, examples of the metal oxide may include lithium oxide (Li<sub>2</sub>O), sodium oxide (Na<sub>2</sub>O), barium oxide (BaO), calcium oxide (CaO), or magnesium oxide (MgO). Examples of the metal salt may include sulfate such as Li<sub>2</sub>SO<sub>4</sub>, Na<sub>2</sub>SO<sub>4</sub>, CaSO<sub>4</sub>, MgSO<sub>4</sub>, CoSO<sub>4</sub>, Ga<sub>2</sub>(SO<sub>4</sub>)<sub>3</sub>, Ti(SO<sub>4</sub>)<sub>2</sub> and NiSO<sub>4</sub>, metal halide such as CaCl<sub>2</sub>, MgCl<sub>2</sub>, SrCl<sub>2</sub>, YCl<sub>3</sub>, CuCl<sub>2</sub>, CsF, TaF<sub>5</sub>, NbF<sub>5</sub>, LiBr, CaBr<sub>2</sub>, CeBr<sub>3</sub>, SeBr<sub>4</sub>, VBr<sub>3</sub>, MgBr<sub>2</sub>, BaI<sub>2</sub> and MgI<sub>2</sub>, and metal chlorate such as Ba(ClO<sub>4</sub>)<sub>2</sub> and Mg(ClO<sub>4</sub>)<sub>2</sub>. Other metal salts may be used.

**[0033]** Further, the pixel array OLED & ITT is formed in the active area AA, on which the image is displayed. The pixel array OLED & TFT includes data lines, scan lines crossing the data lines, and pixels each including an OLED and a TFT. The pixels are also arranged in a matrix form. As shown in FIG. 10, each pixel included in the pixel array OLED & TFT includes a switching TFT SWTFT, a driving TFT DRTFT connected to the switching TFT SWTFT, an OLED connected to the driving TFT DRTFT, and a storage capacitor Cst. Each pixel may further include a compensation circuit for compensating for a threshold voltage and mobility.

**[0034]** In addition, one embodiment of the invention stacks first and second passivation layers PAS1 and PAS2 on the pixel array OLED & TFT, so as to reinforce a barrier covering the pixel array OLED & TFT. The first and second passivation layers PAS1 and PAS2 may be configured as a stack of homogeneous organic/inorganic insulating materials or heterogeneous organic/inorganic insulating materials. As shown in FIG. 4, the second passivation layer PAS2 is diffused to the bottom of the sealant SL. In FIG. 4, "PAD" denotes a data pad or a scan pad connected to an output terminal of a drive

integrated circuit (IC) formed at an end of the data line or the scan line, and "CAT" denotes a cathode of the OLED.

**[0035]** As shown in FIG. 4, the dam DAM may further include a dam bank DAMB for defining an application area of the sealant SL. The dam bank DAMB may be diffused by a pressure generated when the encapsulation plate ENC is attached to the back plane BPL. Further, the dam bank DAMB is formed at a position contacting both edges of a drawing line of the sealant SL in at least one of the encapsulation plate ENC and the back plane BPL and limits the diffusion of the sealant SL.

**[0036]** In addition, a bank pattern may be formed inside the pixel array OLED & TFT of the back plane BPL to limit an area of the pixels. Color filters and black matrixes may be formed on the encapsulation plate ENC. The dam bank DAMB may be formed on the back plane BPL using the same material (for example, an acrylic-based resin) as the bank pattern formed on the back plane BPL. Further, the dam bank DAMB may be formed on the encapsulation plate ENC using the same material as the color filters and the black matrixes formed on the encapsulation plate ENC. The color filters and the black matrixes are formed of an acrylic-based resin, to which a pigment is added.

**[0037]** In another embodiment, as shown in FIG. 5, the dam bank DAME may be formed on the back plane BPL and the encapsulation plate ENC. When the sealant SL is diffused and meets the same structure as the dam bank DAMB, an adhesive angle increases due to surface tension. Hence, the sealant SL does not pass the dam bank DAMB. The height of the dam bank DAMB may be determined depending on a thickness of the bank pattern formed on the back plane BPL or a height of the color filter or the black matrix formed on the encapsulation plate ENC. Further, the surface of the dam bank DAMB may be implemented as a super repellent surface, so as to efficiently prevent the diffusion of the sealant SL. The super repellent surface of the dam bank DAMB may be implemented by adding a hydrophobic material to the dam bank DAMB or performing a hydrophobic process on the surface of the dam bank DAMB.

**[0038]** In still another embodiment, as shown in FIG. 6, the dam DAM may further include a pillar PIL. The material of the pillar PIL is not limited. For example, the pillar PIL may be formed of a glass fiber, a silicon dioxide (SiO<sub>2</sub>) rod or powder, a carbon material, etc. The pillar PIL has the size larger than the moisture absorption filler GT and is distributed in the sealant SL. The pillar PIL thus limits the distance between the back plane BPL and the encapsulation plate ENC inside the dam DAM. Therefore, the pillar PIL prevents the dam DAM from breaking or being damaged because of the pressure generated when the encapsulation plate ENC is attached to the back plane BPL.

**[0039]** Next, FIGS. 7 to 9 are cross-sectional views showing different examples of dam bank patterns of the dam bank shown in FIGS. 4 to 6. In more detail, the dam bank DAMB is omitted on some sides of the sealant SL. That is, as shown in FIGS. 7 to 9, the dam bank DAMB may be formed in at least one of the encapsulation plate ENC and the back plane BPL and be omitted at an inner edge of the sealant SL. For example, as shown in FIG. 7, the dam bank DAMB is formed at positions contacting both edges of the sealant SL at the encapsulation plate ENC and is formed only at a position contacting an outer edge of the sealant SL at the back plane BPL,

**[0040]** In another example as shown in FIG. 8, the dam bank DAMB is formed at outer edges of the sealant SL at the encapsulation plate ENC and the back plane BPL and is not formed at the inner edges of the sealant SL at the encapsulation plate ENC and the back plane BPL. FIG. 9 illustrates the dam bank DMB formed only at outer edges of the sealant SL at the encapsulation plate ENC and the back plane BPL. FIG. 9 also illustrates the pillar PIL described above with respect to FIG. 6.

**[0041]** As described above, the embodiment of the invention attaches the encapsulation plate ENC to the back plane with the dam and the transparent adhesive film interposed therebetween. The dam blocks the moisture from penetrating into the side of the transparent adhesive film, thereby increasing the reliability and the lifespan of the organic light emitting display. Furthermore, the embodiment of the invention increases the transmittance and the aperture ratio of the active area by removing a moisture absorbent film from the transparent adhesive film,

**[0042]** The present invention encompasses various modifications to each of the examples and embodiments discussed herein. According to the invention, one or more features described above in one embodiment or example can be equally applied to another embodiment or example described above. The features of one or more embodiments or examples described above can be combined into each of the embodiments or examples described above. Any full or partial combination of one or more embodiment or examples of the invention is also part of the invention.

**[0043]** Although embodiments have been described with reference to a number of illustrative embodiments thereof, it should be understood that numerous other modifications and embodiments can be devised by those skilled in the art that will fall within the scope of the principles of this disclosure. More particularly, various variations and modifications are possible in the component parts and/or arrangements of the subject combination arrangement within the scope of the disclosure, the drawings and the appended claims. In addition to variations and modifications in the component parts and/or arrangements, alternative uses will also be apparent to those skilled in the art.

What is claimed is:

1. An organic light emitting display, comprising:

a back plane including an active area on which an image is displayed, and a bezel area outside the active area;

a pixel array on the active area and configured to display the image;

an encapsulation plate encapsulating the pixel array;

a transparent adhesive film free of a moisture absorption filler, formed on the active area and disposed between the encapsulation plate and the back plane; and

a dam including a sealant with a moisture absorption filler formed in the bezel area and adjoining the adhesive layer so as to limit moisture from penetrating into the pixel array.

2. The organic light emitting display of claim 1, wherein the dam further includes a dam bank formed at positions contacting both edges of the sealant in at least one of the encapsulation plate and the back plane and configured to limit a diffusion of the sealant.

3. The organic light emitting display of claim 2, wherein the dam bank is formed only at the position contacting both edges of the sealant in the encapsulation plate.

4. The organic light emitting display of claim 2, wherein the dam bank is formed at the positions contacting both edges of the sealant in both the encapsulation plate and the back plane.

5. The organic light emitting display of claim 2, wherein the dam bank is formed at the positions contacting both edges of the sealant in the encapsulation plate and only at an outer edge of the sealant in the back plane.

6. The organic light emitting display of claim 2, wherein the dam bank is formed only at the positions contacting both outer edges of the sealant in the encapsulation plate and the back plane.

7. The organic light emitting display of claim 7, wherein the dam further includes a pillar having a size larger than the moisture absorption filler.

8. The organic light emitting display of claim 7, wherein the pillar has a diameter corresponding to a distance between the encapsulation plate and the back plane.

9. The organic light emitting display of claim 1, further comprising:

first and second passivation layers covering the pixel array.

10. The organic light emitting display of claim 9, wherein the first and second passivation layers are configured as a stack of homogeneous organic/inorganic insulating materials or heterogeneous organic/inorganic insulating materials.

11. The organic light emitting display of claim 9, wherein the first passivation layer covers the pixel array and the second passivation layer is disposed on the first passivation layer.

12. The organic light emitting display of claim 11, wherein the first passivation layer is only disposed in the active area and the second passivation layer is disposed in both the active layer and the bezel area.

13. The organic light emitting display of claim 12, wherein the second passivation layer is diffused to a bottom of the sealant.

14. A method of manufacturing an organic light emitting display, the method comprising:

forming a back plane including an active area on which an image is displayed, and a bezel area outside the active area;

arranging a pixel array configured to display the image on the active area;

forming an encapsulation plate encapsulating the pixel array; and

attaching the back plane and the encapsulation plate via a transparent adhesive film free of a moisture absorption filler, formed on the active area and disposed between the encapsulation plate and the back plane and via a dam including a sealant with a moisture absorption filler formed in the bezel area and adjoining the adhesive layer so as to limit moisture from penetrating into the pixel array.

15. The method of claim 14, wherein the dam further includes a dam bank formed at positions contacting both edges of the sealant in at least one of the encapsulation plate and the back plane and configured to limit a diffusion of the sealant.

16. The method of claim 15, wherein the dam bank is formed only at the position contacting both edges of the sealant in the encapsulation plate.

17. The method of claim 15, wherein the dam bank is formed at the positions contacting both edges of the sealant in both the encapsulation plate and the back plane.

18. The method of claim 15, wherein the dam bank is formed at the positions contacting both edges of the sealant in the encapsulation plate and only at an outer edge of the sealant in the back plane.

19. The method of claim 15, wherein the dam bank is formed only at the positions contacting both outer edges of the sealant in the encapsulation plate and the back plane.

20. The method of claim 15, wherein the dam further includes a pillar having a size larger than the moisture absorption filler.

\* \* \* \* \*

专利名称(译)	有机发光显示器		
公开(公告)号	<a href="#">US20150028307A1</a>	公开(公告)日	2015-01-29
申请号	US14/330924	申请日	2014-07-14
[标]申请(专利权)人(译)	乐金显示有限公司		
申请(专利权)人(译)	LG DISPLAY CO. , LTD.		
当前申请(专利权)人(译)	LG DISPLAY CO. , LTD.		
[标]发明人	KIM KYUNGMAN KIM MYUNGSEOP		
发明人	KIM, KYUNGMAN KIM, MYUNGSEOP		
IPC分类号	H01L51/52 H01L51/56		
CPC分类号	H01L51/5253 H01L51/5259 H01L51/5246 H01L51/56 H01L27/32 H01L51/5237 H01L51/524 H01L27/3244 G02F1/133308 H05B33/04 H01L27/322 H01L27/3246 H01L51/525 H01L51/5256 H01L51/5284 H01L2227/323		
优先权	1020130089590 2013-07-29 KR		
其他公开文献	US9570708		
外部链接	<a href="#">Espacenet</a> <a href="#">USPTO</a>		

摘要(译)

一种有机发光显示器，包括：背板，包括显示图像的有源区域；以及有源区域外的边框区域；活动区域上的像素阵列，用于显示图像；封装像素阵列的封装板；不含吸湿填料的透明粘合膜，形成在有源区上并设置在封装板和背板之间；和包括密封剂的密封剂，所述密封剂具有形成在边框区域中并与粘合剂层邻接的吸湿填料，以限制水分渗透到像素阵列中。

